

**KIT # 8158700**

This kit fits '73-'77 Chevelle/Malibu/El Camino, '73-'77 Oldsmobile Cutlass, '73 Le Mans/Tempest, '73-'77 Grand Prix, '73-'77 Monte Carlo, '73-'77 Buick Century/Regal, all with V8, standard headers, and with 3" collectors at the headers.

**NOTE:** THE HEADERS AND MUFFLERS ARE NOT INCLUDED IN THIS KIT!!

**NOTE:** THE CATALYTIC CONVERTERS ARE NOT SUPPLIED WITH THIS EXHAUST SYSTEM. THIS SYSTEM IS NOT LEGAL FOR ON-ROAD USE ON VEHICLES THAT ORIGINALLY WERE EQUIPPED WITH A CATALYTIC CONVERTER.

**DANGER WARNING:** SHOULD THE PURCHASER DECIDE TO INSTALL THIS EXHAUST PRODUCT AT HOME, BE WARNED THAT PLEASURE CAR OR LIGHT DUTY TRUCK/VAN "BUMPER" JACKS ARE INTENDED FOR EMERGENCY USE ONLY. THE USE OF FRAME CONTACT JACK STANDS IN CONJUNCTION WITH A FLOOR JACK AS MAIN SUPPORT IS HIGHLY RECOMMENDED TO MINIMIZE ACCIDENTAL DROPPING OF A VEHICLE WHILE THE INSTALLATION PROCEEDS.

**HARDWARE KIT:**

- 2) LB9 HANGERS
- 2) SNAPPER GROMMETS
- 4) 5/16" X 1" LAG SCREWS
- 10) 2-1/2" CLAMPS
- 2) F33 FLANGES
- 6) 3/8" NUTS
- 6) 3/8" LOCKWASHERS
- 6) 3/8" X 1-1/4" BOLTS
- 2) FENDER WASHERS (33219)
- 2) #MP48005 3" COLLECTOR GASKETS
- 2) BR755 HANGERS
- 2) BR104 HANGERS
- 2) 5/16" X 1" BOLTS
- 2) 5/16" NUTS
- 1) LEFT COLLECTOR PIPE #E118-1
- 1) RIGHT COLLECTOR PIPE #E118-1
- 2) LEFT & RIGHT FRONT EXTENSION PIPES #E188-2
- 1) LEFT TAIL PIPE #2260037
- 1) RIGHT TAIL PIPE #2260047
- 1) RIGHT OVER THE AXLE PIPE #2260047
- 1) LEFT OVER THE AXLE PIPE #2260037

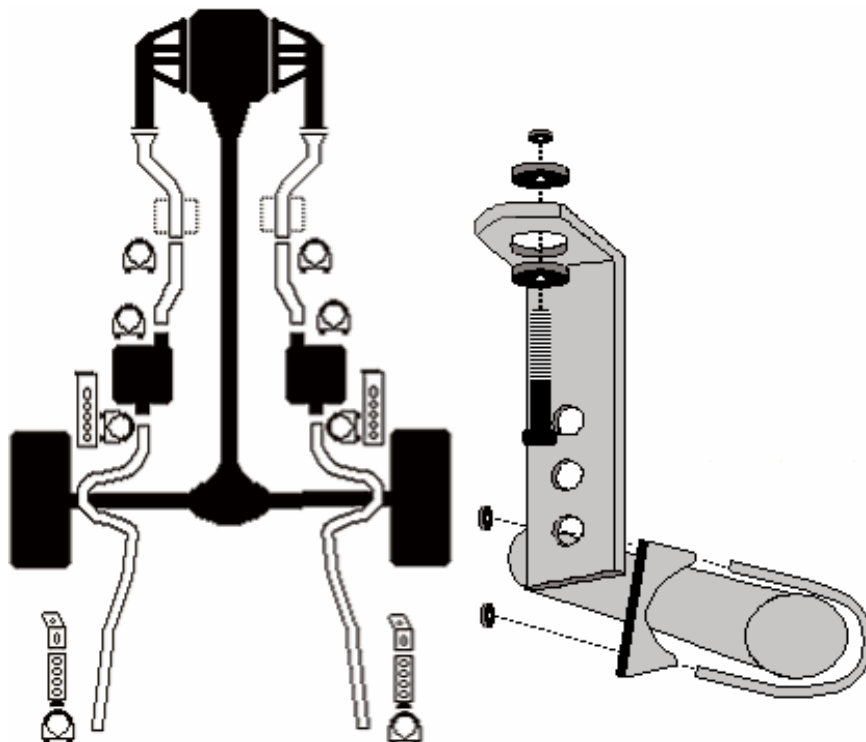

Hanger consists of a metal strap, grommets, hardware and clamp (see illustration).

**KIT # 8158700**

**INSTALLATION INSTRUCTIONS:**

NOTE: DO NOT TIGHTEN ANY CLAMPS OR NUTS UNTIL THE LAST STEP!!

- 1) RAISE THE AUTOMOBILE IN A SAFE AND SUITABLE MANNER--SUPPORT WITH JACK STANDS ONTO THE FRAME.
- 2) REMOVE THE OLD EXHAUST SYSTEM AFTER THE HEADERS. REMOVE THE OLD HANGERS AND BRACKETS IF DESIRED. NEW UNIVERSAL HANGERS ARE INCLUDED IN THIS KIT TO REPLACE THE ORIGINAL HANGERS.
- 3) INSTALL THE LEFT AND RIGHT COLLECTOR PIPES USING THE MP48005 GASKETS AND F33 FLANGES. TIGHTEN ONLY ENOUGH TO HOLD IN PLACE, USING THE 3/8" X 1-1/4" BOLTS AND NUTS. **NOTE:** FOR VEHICLES REQUIRING CATALYTIC CONVERTERS TO MEET EPA GUIDELINES, CATALYTIC CONVERTER #73-7774 OR EQUIVALENT SHOULD BE INSTALLED ON THE HEADER COLLECTOR PIPES AFTER THE HEADER COLLECTORS ON THE COLLECTOR PIPES.
- 4) INSTALL THE LEFT AND RIGHT FRONT EXTENSION PIPES TO THE COLLECTOR PIPES USING 2-1/2" CLAMPS. BE SURE TO LEAVE ADEQUATE CLEARANCE BETWEEN THE FLOOR BOARDS AND THE DRIVE SHAFT.
- 5) INSTALL THE MUFFLERS (OFFSET IN/CENTER OUT, NOT INCLUDED) ONTO THE FRONT EXTENSION PIPES USING 2-1/2" CLAMPS. ROTATE THE FRONT EXTENSION PIPES TO CLEAR THE DRIVESHAFT, AND FRAME, AND GENERAL CLEARANCE.
- 6) MOUNT THE HANGER BRACKETS IF NECESSARY TO THE FRAME USING THE LB9 STRAP WITH THE GROMMETS AND LAG SCREW BEHIND THE MUFFLERS, AND THE BR755 BRACKET, LAG SCREW, AND BR104 RUBBER HANGER AT THE END OF THE TAIL PIPES. CONNECT THE HANGERS TO THE PIPES USING THE 2-1/4" CLAMPS.
- 7) INSTALL THE LEFT AND RIGHT OVER THE AXLE PIPES TO THE MUFFLERS USING 2-1/2" CLAMPS. INSTALL THE LEFT AND RIGHT TAIL PIPES TO THE OVER THE AXLE PIPES USING 2-1/2" CLAMPS. USE A 2-1/2" CLAMP TO CONNECT THE PIPES AND A HANGER AT THE REAR. CUT THE TAIL PIPES TO YOUR DESIRED LENGTH AND LOOK.

8) MAKE SURE THAT ALL THE PARTS OF THE SYSTEM ARE CLEAR OF FRAME MEMBERS, ALL HOSES, SUSPENSION, AND BRAKE AND FUEL LINES. STARTING AT THE COLLECTOR PIPES, TIGHTEN ALL CONNECTIONS AND NUTS. MAKE SURE ALL PARTS ARE CLEAR AND WILL NOT LEAK OR RATTLE. AFTER SEVERAL DAYS OF DRIVING RETIGHTEN ALL BOLTS.

LIMITATION OF LIABILITY-DISCLAIMERS: THE REGULATION OF EMISSIONS PRODUCTION, NOISE LEVELS AND SAFETY STANDARDS IS UNDERTAKEN BY THE FEDERAL GOVERNMENT, EACH OF THE FIFTY STATE LEGISLATURES, AND BY MANY LOCAL MUNICIPALITIES, TOWNS AND COUNTIES.

THE MANUFACTURER MAKES NO WARRANTIES OF MERCHANTABILITY, OF FITNESS FOR A PARTICULAR PURPOSE, OR THAT ITS PRODUCTS ARE APPROVED FOR GENERAL USE, OR THAT ITS PRODUCTS COMPLY WITH LAWS, REGULATIONS OR ORDINANCES IN THE STATES WHERE THEY MAY BE SOLD TO THE ULTIMATE PURCHASER, THE CONSUMER.

THE ENTIRE RISK AS TO THE CONFORMITY OF THIS PRODUCT IN ANY SUCH STATE AND AS TO REPAIR, SHOULD THE PRODUCT PROVE TO BE DEFECTIVE OR NON-CONFORMING, IS ON THE RETAIL PURCHASER, THE BUYER, THE ULTIMATE CONSUMER, OF SUCH PRODUCT AND IT IS NOT UPON THE SELLER, DISTRIBUTOR, OR MANUFACTURER.

IN THIS CONNECTION, THE RETAIL PURCHASER, THE BUYER, THE ULTIMATE CONSUMER ASSUMES THE BURDEN OF THE ENTIRE COST OF ANY AND ALL NECESSARY SERVICE, ALTERATIONS AND OR REPAIR.

THE FOREGOING STATEMENT LIMITS THE LIABILITY OF THE MANUFACTURER.

CALIFORNIA VEHICLE CODE SECTION 27156 PROHIBITS THE ADVERTISING, OFFERING FOR SALE, OR INSTALLATION OF ANY DEVICE WHICH MODIFIES A VEHICLE'S EMISSION CONTROL SYSTEM. THIS PRODUCT IS THEREFORE NOT LEGAL FOR SALE OR USE IN CALIFORNIA ON VEHICLES EQUIPPED WITH CATALYTIC CONVERTERS.



Heartthrob exhaust systems are manufactured by Heartthrob Exhaust--Litchfield, MN

Email us at [mike@heartthroboxhaust.com](mailto:mike@heartthroboxhaust.com) with any questions.

**BUILD SHEET FOR: HEADER DUAL KIT**

PART #'S: 8158700

- \_\_\_\_\_ 1) LEFT COLLECTOR PIPE#E118-1;2.5
- \_\_\_\_\_ 1) RIGHT COLLECTOR PIPE#E118-1;2.5
- \_\_\_\_\_ 2) LEFT & RIGHT FRONT EXTENSION PIPES#E118-2;2.5
- \_\_\_\_\_ 1) LEFT OVER THE AXLE PIPE#2260037
- \_\_\_\_\_ 1) RIGHT OVER THE AXLE PIPE#2260047
- \_\_\_\_\_ 1) LEFT TAIL PIPE#2260047
- \_\_\_\_\_ 1) RIGHT TAIL PIPE#2260037
- \_\_\_\_\_ 1) HARDWARE KIT

INSPECTED BY: \_\_\_\_\_

DATE: \_\_\_\_\_

INSPECTED BY: \_\_\_\_\_

DATE: \_\_\_\_\_

**BUILD SHEET FOR: HEADER DUAL KIT**

PART #'S: 8158700

- \_\_\_\_\_ 1) LEFT COLLECTOR PIPE#E118-1;2.5
- \_\_\_\_\_ 1) RIGHT COLLECTOR PIPE#E118-1;2.5
- \_\_\_\_\_ 2) LEFT & RIGHT FRONT EXTENSION PIPES#E118-2;2.5
- \_\_\_\_\_ 1) LEFT OVER THE AXLE PIPE#2260037
- \_\_\_\_\_ 1) RIGHT OVER THE AXLE PIPE#2260047
- \_\_\_\_\_ 1) LEFT TAIL PIPE#2260037
- \_\_\_\_\_ 1) RIGHT TAIL PIPE#2260047
- \_\_\_\_\_ 1) HARDWARE KIT

INSPECTED BY: \_\_\_\_\_

DATE: \_\_\_\_\_

INSPECTED BY: \_\_\_\_\_

DATE: \_\_\_\_\_